



CATALOGUE

2014

TTABN-Series of Slurry pump



PRODUCT BROCHURE

TORONTECH
PUMPS

TORONTECH.COM



Torontech™ is a leading North American based international manufacturer and supplier of pumps, pipes, valves & actuators. The Torontech™ group has established an extensive network in the USA as well as international markets and remains to be a preferred vendor of choice supplying quality pumps for today's leading corporations.

Creating comprehensive solutions for our clients has always been the core value of our company. From sales, to order execution, and post-sales support; every staff member is here to assist you in selecting the solution that best suits your unique requirements and budget.

The Torontech™ group offers a complete range of quality pumps that are ANSI to ISO approved and engineered to last, ensuring your company continuous production without interruptions.

Since the beginning, we have succeeded in only offering quality manufactured pumps that are currently being used worldwide. We offer the best value for your investment and provide world-class support.

Due to the demand for our quality pumps, Torontech™ has experience explosive growth primarily in the oil & gas, water filtration and chemical refinery industries.

We offer an extensive range of solutions and products for oil & gas projects, refineries, petrochemical plants, and marine applications. Our main class of pumps includes API (American Petroleum Institute) Standard, Mining, Water & Sewage and Firefighting applications. The pumps are offered in various configurations depending on orientation of the pump, required head and type of fuel used for operation.



TTABN-Series of Slurry pump

TTABN-Series of Slurry pump

General information

Features of product



(1)the slurry pump series is energy efficient, single-stage, single-use, cantilevered pump, for pumping contain particles of abrasive or corrosive slurry, which is widely used in the power, mining, metallurgy, coal, building materials, chemicals, food, water and sewage treatment industries

(2)The series is more 50 models, it can add more than 300 by change speed for the user to choose.

(3)According as your slurry transportation Physics (particle composition, size, shape, hardness, strength) and chemical (acid, Base oil) characteristic, it will select material of flowing part. Users should be set loan note for the use of appropriate materials

(4)Pump drive include direct and belt in two forms. Direction from the motor to see, it is for the clockwise direction of rotation.

(5)Model meaning:

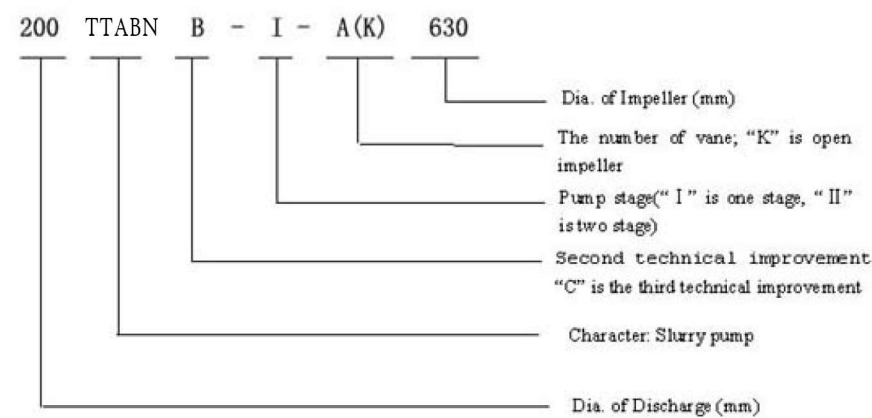

Aim at slurry pump three technology puzzle: short life、hard seal、more expend energy , we are made in particular type TTABN the two-phase flow slurry pump for according to technology design. Because of the slurry pump water power design by sufficient advisement, so the slurry pump can keep nice capability. As follow it is Feature:

(1).High efficiency and economize energy: the two-phase flow slurry pump is efficiency the higher than normal pump and slurry pump. This is because the hydraulic pump design is based on solid-liquid two-phase design. of water and slurry transportation to the speakers, adapt better to the slurry transportation or a drop of the two-phase pump to improve the operation efficiency 3~10%. So the two-phase flow pump with a new energy conversion law

(2)Corrosion-resistant, long life : general slurry pump operate, solids is the main strike and abrasion, the NPSH performance increase with the flow worsened. And the two-phase flow of slurry pump design with solid flow of change, and solid along the vane run. The impeller is friction and wear, pump NPSH performance increase with the flow of change relatively stable. Therefore the two-phase flow pump with the new law of wear. Under the same conditions, the two-phase pump life than the general slurry pump long life more than 20%, suction head increase 1-meter..

(3).Economize water, the suitable for high-thickness transportation: Normal slurry pump performance get worse with the higher thickness of the slurry. And the two-phase pump hydraulic design of solid full consideration (including concentration, Dia. of solid, shape, etc.) run , the supply of high concentration (general thickness γG is 60%~70%) slurry still have good water behavior ,it is satisfies for process requirement of high thickness. Therefore the two-phase flow slurry pump is satisfies for high-thickness.

(4) TTABN series slurry pump company exclusive use of the special structure, This series of products is based on our Coal filter technology and the special needs of the single-stage design of slurry pump. When the filter press work, the pump flow become smaller, the pressure increase due process requirements, pump shaft seal Department allowed into sealed water. Packing Department to be leaking slurry (even if Deputy impeller dynamic seal useless), environmental pollution, Seal packing destruction, the scene of increased maintenance workload and reduce the pump overhaul life. The pump series features: in the absence of sealing water conditions to ensure that there will not be packing slurry leak. The series can also be used to pump slurry pump into the mouth of the burial I pressures not exceeding IOM, and no water seal of occasions. Its performance parameters and installation of the same size and type slurry pump hydraulic exactly the same.

Principle of work

The slurry pump is a centrifugal pump series. When the motor drive impeller shaft rotation, the slurry is do circular motion with impeller. A side of the centrifugal impeller under since dished out from the center circle. When the pressure of slurry from the impeller and were able to pressure and the flow rate can scroll to the liquid discharge mouth, Some can change the speed of static pressure can be. When the slurry dished out by the impeller, the impeller area of low pressure center formed, then slurry constantly be inhaled, and to a certain pressure discharge.

Technical information

Capacity: 4~7960m³/h , Head:1.4~133m , Max. solid granule:120MM. Need NPSHr:1.3~10 m



TORONTECH™

Pumps and Valves

TTABN



TORONTECH™

Torontech™ – North America
TEL:+1 (416) 368-2721
FAX:+1 (416) 981-7652
E-MAIL: sales@Torontech.com
WEB:www.Torontech.com

Please contact us for your nearest local office or distributor

Torontech Inc. - Canada
North American Headquarters
Tel: +1.416.368.2721
Fax: +1.416.981.7652
Email: sales@torontech.com
www.Torontech.com

Torontech Inc. - Canada
North American Headquarters
Tel: +1.416.368.2721
Fax: +1.416.981.7652
Email: sales@torontech.com
www.Torontech.com